

Genie® S®-60 DC & S-60 FE

Specifications

Models	S-60 DC & S-60 FE
Working height max. ⁽¹⁾	20.60 m
Platform height max.	18.60 m
Horizontal reach max.	12.30 m
A Platform length (8 ft/6 ft)	0.91 m/0.76 m
B Platform width (8 ft/6 ft)	2.44 m/1.83 m
C Height - stowed	2.73 m
C Height - storage/transport (jib tucked under)	2.92 m
D Length - stowed	9.65 m
D Length - storage/transport (jib tucked under)	7.16 m
E Width	2.49 m
F Wheelbase	2.49 m
G Ground clearance - center	0.46 m

Productivity

Lift capacity max. - unrestricted	300 kg
Number of Platform Occupants	2
Platform rotation	160°
Jib length	1.83 m
Vertical jib rotation (up/down)	130°
Turntable rotation	353°
Turntable tailswing (riser up/riser down)	1.24 m/1.57 m
Drive speed - stowed	6.44 km/h
Drive speed - raised	1.1 km/h
Gradeability - stowed ⁽²⁾	45%
Turning radius - inside/outside	3.06 m/5.25 m
Tires	355/55D625

Power

Drive System	48V 3-Phase AC
Battery Pack, DC	48V DC (8×6V), 390Ah, FLA
Battery Pack, FE	48V DC (8×6V), 370Ah, AGM
AC generator, FE	Diesel
Auxiliary power unit, FE	12V DC
Hydraulic tank capacity	68 L
Fuel tank capacity	64 L

Weight⁽³⁾ and Floor Loading⁽⁴⁾

Weight, DC	7,983 kg
Weight, FE	8,051 kg
Tire contact pressure	500 kPa
Occupied floor pressure	9.74 kPa

Sound and Vibration Levels

Sound Pressure level (ground workstation)	70 dBA (DC)/83 dBA (FE)
Sound Pressure level (platform workstation)	70 dBA (DC)/76 dBA (FE)
Vibrations	0.34 m/s ²

Range of motion S-60 DC/S-60 FE

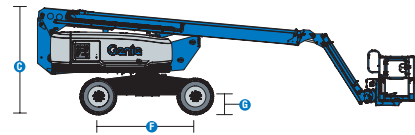
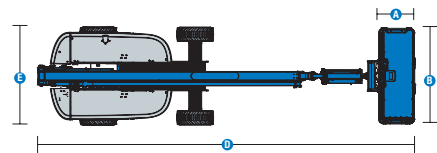
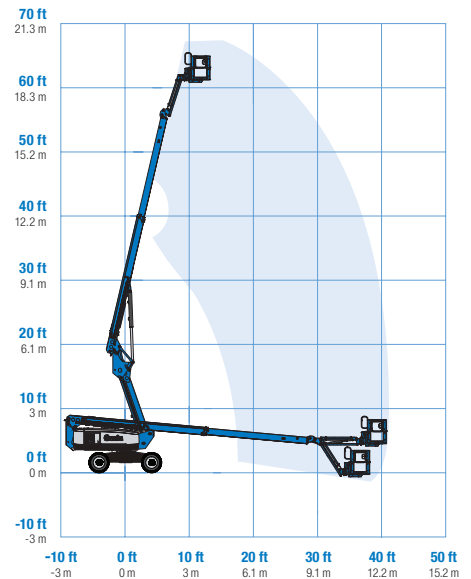

(1) The metric equivalent of working height adds 2 m to platform height. The imperial equivalent adds 6 ft to platform height.

(2) Gradeability applies to driving on slopes and may vary depending on options and machine configurations. See operator's manual for details regarding slope ratings.

(3) Weight refers to standard configuration and may vary depending on options and/or country standards.

(4) Floor loading information is approximate and may vary depending on options and machine configurations. It should be used only with adequate safety factors.

Genie® S®-60 DC & S-60 FE

SKU: Standard Model

- S-60 DC, DC Power, 4WD*
- S-60 FE, 4WD*

* Build to Order

Option availability		S	S+	BtO
Power	24.8 hp, 18.5 kW, Kubota D1105, Diesel, T4i/T4f, Stage IIIA/IV, CN III (FE model only)			✓
	FLA flooded lead acid batteries (Standard on DC)			○
	AGM Maintenance-free batteries (Standard on FE)			✓
	Power inverter, 2kW, 110V/50Hz			○
	Power inverter, 2kW, 120V/60Hz			○
	Power inverter, 2kW, 220V/50Hz			○
	12V DC auxiliary power unit			✓
	3-phase AC drive system			✓
	48V solid state battery charger			✓
	Low voltage interrupt (LVI) with battery charge indicator (BCI)			✓
Platform	6ft/1.83m dual-entry platform with side swing gate			○
	8ft/2.44m tri-entry platform with side swing gate			✓
	Power to platform with RCBO			○
	Thumb rocker steering			✓
	Air line to platform			○
	Control box covers			○
	Lift Guard Full Mesh panels			○
	Lift Guard Half Mesh panels			○
	Light Package: drive and work lights			○
	Platform auxiliary top rail			○
	AC Power cord to platform			✓
	Drive enable system			✓
	Horn			✓
	Lift Guard Contact Alarm			✓
	Lift Tools Work Tray			✓
	Platform load sense system			✓
	Proportional controls			✓
	Self-leveling platform			✓
Travel alarm package: flashing beacons, descent, travel and tilt alarms			✓	
Chassis	Lift Connect Telematics			○
	Lift Connect with Access Manager upgrade			○
	Eco32 biodegradable hydraulic oil			○
	Rough terrain, foam-filled tires			○
	Rough terrain, foam-filled, non-marking tires			✓
	Chassis tilt lift function cut-out			○
	Hostile environment kit			○
	Tow package			○
	Chassis tilt drive function cut-out			✓
	Electric brake release			✓
Hour meter			✓	
On-board diagnostic system			✓	

- S Standard
- S+ Standard +
- BtO Build to Order
- ✓ Standard Features
- Options



4 AC Drive motors



Rugged Terrainability



Low Noise, Low Emissions



Genie Genuine Accessories⁽¹⁾

- Lift Tools Productivity Tools
- Tech Pro Link Handheld Device

(1) More accessories available from Genie Genuine Parts.

Product specifications are subject to change without notice or obligation. Photographs and/or drawings herein are for illustrative purposes only. Refer to the appropriate Operator's Manual for instructions on proper equipment use. Failure to follow instructions in the Operator's Manual may result in serious injury or death. The only warranty applicable to our equipment is the standard written warranty applicable to the particular product and sale and we make no other warranty, express or implied. Products and services listed may be trademarks, service marks or trade names of Terex Corporation and/or their subsidiaries in the USA and many other countries. Terex, Genie, Quality By Design, Xtra Capacity, Lift Power, Lift Guard, Lift Tools, Lift Connect and Tech Pro Link are registered trademarks of Terex Corporation or its subsidiaries.