

Genie® GS™ -4046

Specifications

Models	GS-4046	
Measurements	US	Metric
Working height max. - indoor ⁽¹⁾	45 ft 2 in	13.94 m
Working height max. - outdoor ⁽¹⁾	29 ft	9.00 m
A Platform height max. - indoor	39 ft 2 in	11.94 m
A Platform height max. - outdoor	23 ft	7.01 m
B Platform height - stowed	4 ft 9 in	1.45 m
C Platform length - outside	7 ft 5 in	2.26 m
C Platform length - outside, extended	10 ft 5 in	3.18 m
Slide-out platform extension deck - length	3 ft	0.91 m
D Platform width - outside	3 ft 10 in	1.18 m
Guardrail height	3 ft 7 in	1.10 m
Toeboard height	6 in	15 cm
E Machine Height - stowed (folding rails)	8 ft 5 in	2.57 m
Machine Height - stowed (rails lowered)	6 ft 6 in	1.98 m
F Length machine - stowed	8 ft 2 in	2.48 m
F Length machine - stowed, extended	11 ft 6 in	3.51 m
G Width	3 ft 10 in	1.18 m
H Wheelbase	6 ft 1 in	1.85 m
I Ground clearance (center) - pothole guards retracted	5 in	12 cm
I Ground clearance - pothole guards deployed	0.9 in	2.30 cm

Productivity

Max. platform occupancy (in/out)	3/1	
Lift capacity	770 lb	350 kg
Lift capacity - extension deck extended	250 lb	113 kg
Max. platform drive height	39 ft 2 in	11.94 m
Drive speed - stowed	2.0 mph	3.2 km/h
Drive speed - raised	0.5 mph	0.8 km/h
Gradeability - stowed ⁽²⁾	25%	
Turning radius - inside/outside	0/7 ft 6 in	0/2.29 m
Lifting speed - raise/lower	71/41 sec	
Tilt sensor activation (front to back/side to side)	3° / 1.5°	
Tires - solid non-marking	15×5 in	38×13 cm

Power

Power	24V DC (4×12V 300Ah)	
Hydraulic tank capacity (E-Drive)	4.9 gal	18.5 L

Weight⁽³⁾ and Floor Loading⁽⁴⁾

Weight	6,871 lb	3,117 kg
Weight max. (adding all possible options)	7,022 lb	3,185 kg
Tire load max.	2,735 lb	1,241 kg
Tire contact pressure	170.3 psi	1,174 kPa
Occupied floor pressure	275 psf	13.17 kPa

Sound and Vibration Levels

Sound Pressure level (ground workstation)	< 70 dBA	
Sound Pressure level (platform workstation)	< 70 dBA	
Vibrations	< 8 ft 2 in/s ²	< 2.5 m/s ²

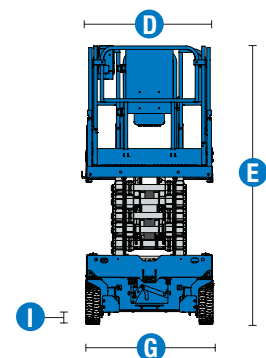
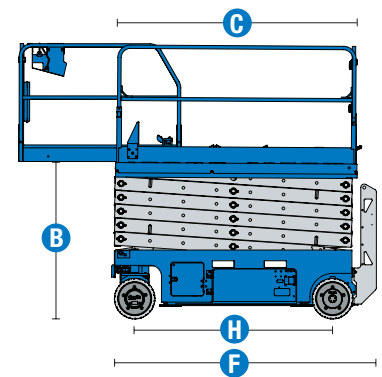
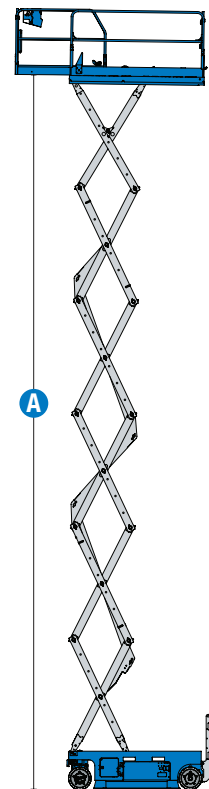

(1) The metric equivalent of working height adds 2m to platform height. US adds 6ft to platform height.

(2) Gradeability applies to driving on slopes and may vary depending on options and machine configurations. See operator's manual for details regarding slope ratings.

(3) Weight refers to standard configuration and may vary depending on options and/or country standards.

(4) Floor loading information is approximate and may vary depending on options and machine configurations. It should be used only with adequate safety factors.

Genie® GS™ -4046

SKU: Standard Model

- **GS4046E1AE0002:** GS-4046, E-Drive

* Build to Order

Option availability		S	S+	BtO
Power	Standard FLA flooded lead acid batteries	✓	✓	✓
	Drive cut-out while charging		○	○
	Power Inverter		○	○
	Rear recessed charger receptacle	✓	✓	✓
Platform	Folding rails, Full-height swing gate	✓	✓	✓
	Slide out extension deck	✓	✓	○
	Air line to platform			○
	Automotive-style horn		○	○
	AC power to platform	✓	✓	✓
	Descent, tilt and motion alarm	✓	✓	✓
	Diamond plate platform deck	✓	✓	✓
	Dual LED flashing beacons	✓	✓	✓
	Electric horn	✓	✓	✓
	Lanyard attachment points	✓	✓	✓
	Platform control guard (PCON)	✓	✓	✓
	Platform load sense system	✓	✓	✓
	Proportional drive and lift	✓	✓	✓
	SmartLink dual zone control system	✓	✓	✓
Chassis	Lift Connect Telematics		○	○
	Lift Connect with Access Manager upgrade		○	○
	Lift Guard White Noise Alarm		○	○
	Lift Tools Spill Guard (E-Drive)			○
	Auxiliary platform lowering	✓	✓	✓
	Driveable at full height	✓	✓	✓
	Dual front wheel sealed AC electric drive motors (E-Drive)	✓	✓	✓
	Dual wheel multi-disc brakes	✓	✓	✓
	Electric brake release (E-Drive)	✓	✓	✓
	On board diagnostic system with battery charge indicator	✓	✓	✓
	Pothole protection	✓	✓	✓
	Side and rear fork pockets	✓	✓	✓
Solid non-marking tires	✓	✓	✓	
Tech Pro Link connector	✓	✓	✓	
Tie-down and lifting points	✓	✓	✓	

- S Standard
- S+ Standard +
- BtO Build to Order
- ✓ Standard Features
- Options



Indoor & Outdoor Use



Side Forklift Pockets



E-Drive



Genie Genuine Accessories⁽¹⁾

- Lift Tools Productivity Tools
- Lift Connect Telematics
- Tech Pro Link Handheld Device

(1) More accessories available from Genie Genuine Parts.

Product specifications are subject to change without notice or obligation. Photographs and/or drawings herein are for illustrative purposes only. Refer to the appropriate Operator's Manual for instructions on proper equipment use. Failure to follow instructions in the Operator's Manual may result in serious injury or death. The only warranty applicable to our equipment is the standard written warranty applicable to the particular product and sale and we make no other warranty, express or implied. Products and services listed may be trademarks, service marks or trade names of Terex Corporation and/or their subsidiaries in the USA and many other countries. Terex, Genie, Quality By Design, Xtra Capacity, Lift Power, Lift Guard, Lift Tools, Lift Connect and Tech Pro Link are registered trademarks of Terex Corporation or its subsidiaries.