

# Genie® GS™ -2669 RT, GS-3369 RT & GS-4069 RT

## Specifications

Models	GS-2669 RT	GS-3369 RT	GS-4069 RT
Working height max. <sup>(1)</sup>	10 m	11.96 m	14.3 m
<b>A</b> Platform height max.	8 m	9.96 m	12.3 m
<b>B</b> Platform height - stowed	1.47 m	1.47 m	1.65 m
<b>C</b> Platform length - outside	2.79 m	2.79 m	2.79 m
Platform length - outside, extended	4.32 m	4.32 m	4.32 m
Slide-out platform extension deck - length	1.52 m	1.52 m	1.52 m
<b>D</b> Platform width - outside	1.60 m	1.60 m	1.60 m
Toeboard height	15 cm	15 cm	15 cm
<b>E</b> Height - stowed (folding rails) <sup>(2)</sup>	2.59 m	2.59 m	2.74 m
Height - stowed (rails lowered)	1.92 m	1.92 m	2.08 m
<b>F</b> Length machine - stowed	3.12 m	3.12 m	3.12 m
Length machine - stowed, extended	4.5 m	4.5 m	4.5 m
Length machine - with outriggers	3.76 m	3.76 m	3.76 m
<b>G</b> Width	1.75 m	1.75 m	1.75 m
<b>H</b> Wheelbase	2.29 m	2.29 m	2.29 m
<b>I</b> Ground clearance (center)	24 cm	24 cm	24 cm

## Productivity

Max. platform occupancy (in/out)	4/4	4/2	3/2
Lift capacity	680 kg	454 kg	363 kg
Lift capacity - extension deck extended	136 kg	136 kg	136 kg
Max. platform drive height	5.85 m	9.96 m	12.3 m
Drive speed - stowed	5.6 km/h	5.6 km/h	5.6 km/h
Drive speed - raised	0.5 km/h	0.5 km/h	0.5 km/h
Gradeability - stowed <sup>(3)</sup>	40 %	35 %	35 %
Turning radius - inside/outside	2.11 m/4.6 m	2.11 m/4.6 m	2.11 m/4.6 m
Lifting speed - raise/lower	34/31 sec	39/29 sec	61/28 sec
Tilt sensor activation (front to back/side to side)	3°/2°	3°/2°	3°/2°
Max. outrigger leveling (front to back /side to side)	5.3°/11.7°	5.3°/11.7°	5.3°/11.7°

## Drive

Tires - Foam-filled rough terrain	30×66 cm	30×66 cm	30×66 cm
-----------------------------------	----------	----------	----------

## Power

Power	Diesel	Diesel	Diesel
Fuel Tank	37.9L	37.9L	37.9L
Hydraulic tank capacity	68.1L	68.1L	68.1L

## Weight<sup>(4)</sup> and Floor Loading<sup>(5)</sup>

Weight	3,243 kg	3,447 kg	4,714 kg
Weight with outriggers	3,629 kg	3,833 kg	5,100 kg
Tire load max.	1,288 kg	1,369 kg	1,737 kg
Tire contact pressure - front, platform fully extended	487 kPa	518 kPa	657 kPa
Occupied floor pressure	8.15 kPa	8.11 kPa	10.29 kPa

## Sound and Vibration Levels

Sound Pressure level (ground workstation)	85 dBA	85 dBA	85 dBA
Sound Pressure level (platform workstation)	79 dBA	79 dBA	79 dBA
Vibrations	< 2.5 m/s <sup>2</sup>	< 2.5 m/s <sup>2</sup>	< 2.5 m/s <sup>2</sup>

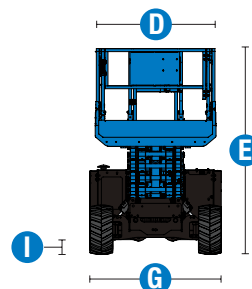
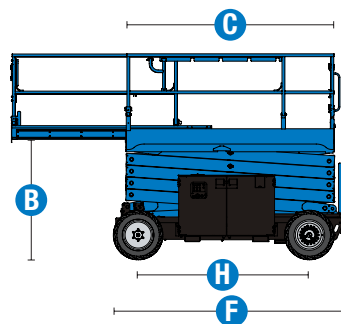
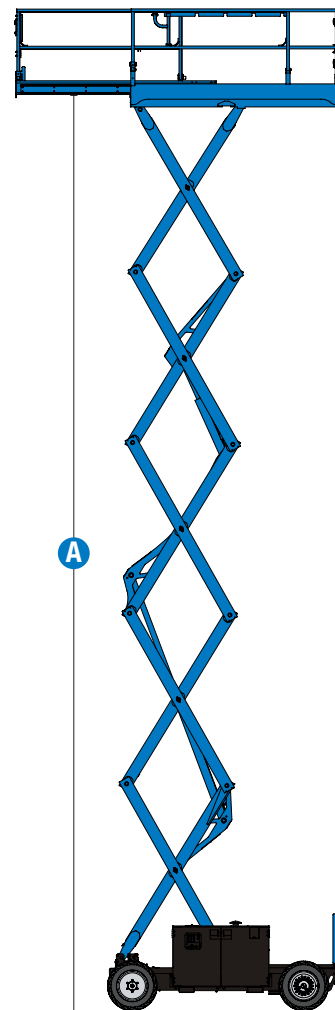

(1) The metric equivalent of working height adds 2 m to platform height. US adds 6 ft to platform height.

(2) Based on RT tires; deduct 2 in/5.8 cm for turf and non-marking tires.

(3) Gradeability applies to driving on slopes and may vary depending on options and machine configurations. See operator's manual for details regarding slope ratings.

(4) Weight refers to standard configuration and may vary depending on options and/or country standards.

(5) Floor loading information is approximate and may vary depending on options and machine configurations. It should be used only with adequate safety factors.

# Genie® GS™ -2669 RT, GS-3369 RT & GS-4069 RT

## SKU: Standard Model

- GS-4069 RT\*
- GS-3369 RT\*
- GS-2669 RT\*

\* Build to Order

Option availability		S	S+	BtO
Power	24.8 hp, 18.5 kW Kubota D1105, Diesel, T4i/T4f, Stage IIIA/IV, CN III			✓
Platform	Folding rails, Full-height swing gate			✓
	Single slide-out extension deck			✓
	Air line to platform			○
	3kW AC Generator, 110V/50Hz			○
	3kW AC Generator, 220V/50Hz			○
	AC power to platform			✓
	Diamond plate platform deck			✓
	Electronic horn			✓
	Lanyard attachment points			✓
	Platform control guard (PCON)			✓
	Platform control with fault indicator			✓
	Platform load sense system			✓
	Proportional drive and lift			✓
	Self-closing entry gate			✓
	Chassis	Lift Connect Telematics		
Lift Connect with Access Manager upgrade				○
Biodegradable hydraulic oil				○
Rough Terrain, foam-filled tires				✓
Rough Terrain, foam-filled, non-marking tires				○
4 wheel drive				✓
Active oscillating axle				✓
Auto leveling hydraulic outriggers				✓
Descent, tilt and motion alarm				✓
Dual LED flashing beacons				✓
Dual wheel multi-disc brakes			✓	
Hydraulic oil cooler			✓	

- S Standard
- S+ Standard +
- BtO Build to Order
- ✓ Standard Features
- Options



4 Wheel Drive

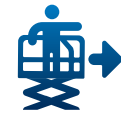

Full Height Drive



Swing-Out Engine Tray



### Genie Genuine Accessories<sup>(1)</sup>

- Lift Tools Productivity Tools
- Lift Connect Telematics
- Tech Pro Link Handheld Device

(1) More accessories available from Genie Genuine Parts.

Product specifications are subject to change without notice or obligation. Photographs and/or drawings herein are for illustrative purposes only. Refer to the appropriate Operator's Manual for instructions on proper equipment use. Failure to follow instructions in the Operator's Manual may result in serious injury or death. The only warranty applicable to our equipment is the standard written warranty applicable to the particular product and sale and we make no other warranty, express or implied. Products and services listed may be trademarks, service marks or trade names of Terex Corporation and/or their subsidiaries in the USA and many other countries. Terex, Genie, Quality By Design, Xtra Capacity, Lift Power, Lift Guard, Lift Tools, Lift Connect and Tech Pro Link are registered trademarks of Terex Corporation or its subsidiaries.